

Waste Conveyors

WASTE CONVEYORS FOR THREE-KNIFE TRIMMERS

- MODEL SERIES 2014 -

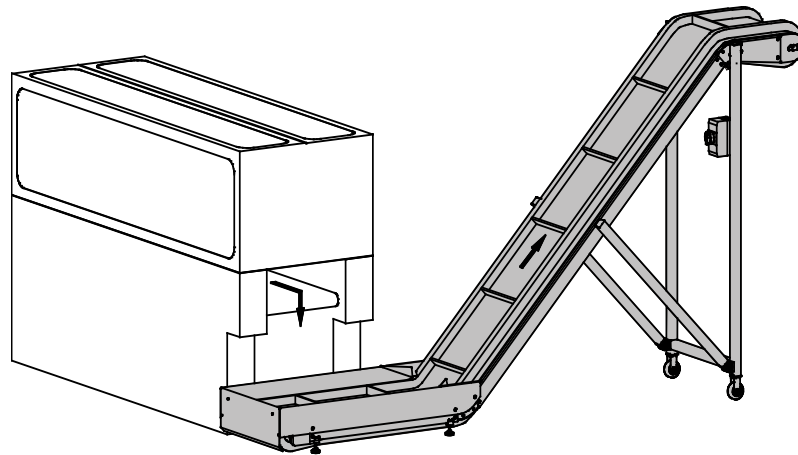

KF 145-80

Waste conveyor with lengthened delivery chute of 800 mm

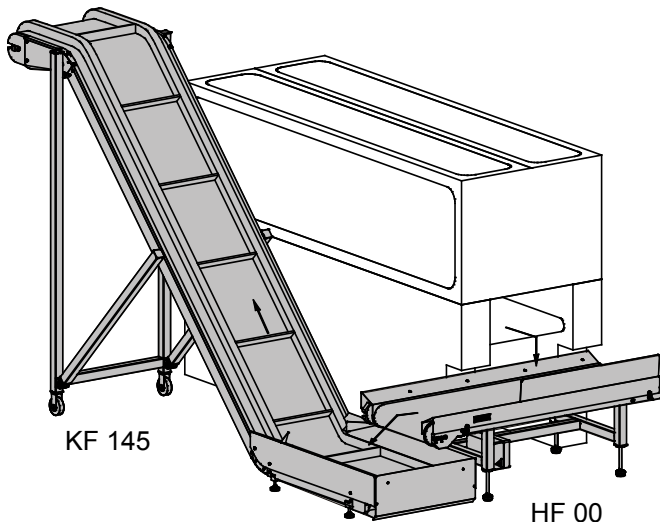

KF 145

HF 00

Combination for three-knife trimmer with internal conveyor

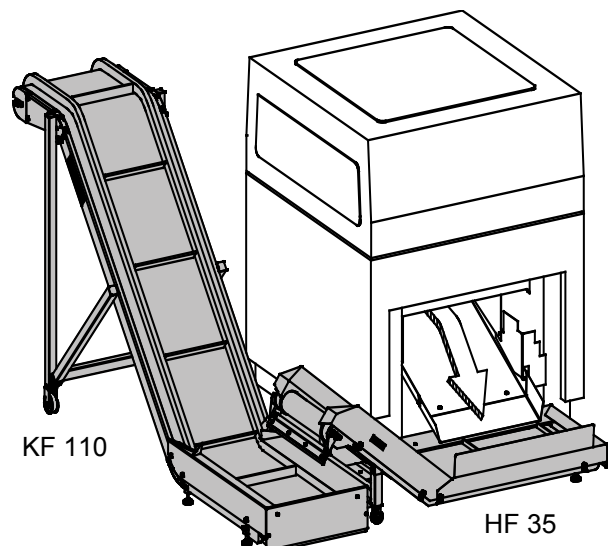

KF 110

HF 35

Combination for three-knife trimmer with internal waste chute

WASTE CONVEYORS FOR THREE-KNIFE TRIMMERS

- MODEL SERIES 2014 -

<p>KF For the removal of cut waste conveyed into containers (e.g. on automatic punching machines, saddle stitchers or perfect binders with three-knife trimmer and to other machinery).</p> <p>HF For the cross transport of waste discharged under the producing machine (e.g. three-knife trimmer) conveyed on to the KF</p>									
									<p>Model</p>
Conveying height	mm	1100	1100	1450	1450	1750	1750	350	-
Length of delivery chute	mm	600	800	600	800	600	800	800	1000
Conveying speed	m/s	0,4	0,4	0,4	0,4	0,4	0,4	0,4	0,4
Power requirements (3-ph.)	kW	0,3	0,3	0,3	0,3	0,3	0,3	0,12	0,12
Power consumption 230/400V	A	0,6	0,6	0,6	0,6	0,6	0,6	0,25	0,25
Dimensions	mm								
Length		2485	2685	2835	3035	3135	3335	1520	1260
Height		1310	1310	1660	1660	1960	1960	545	440
Width		625	625	625	625	625	625	580	580
Net weight	kg	88	94	102	108	114	120	45	43